

plex most obstinately. Indeed, these authors suggest that even glass might adsorb sufficient silver chloride to account for losses observed on standing.<sup>7</sup> Another possibility is that chloride solutions, in the absence of much adsorbing solid, peptize silver chloride in a strictly reproducible fashion.<sup>8</sup> If so, the degree of dispersion must be very high. The possibility that more than one form of silver chloride with different solubilities may exist, is not excluded. The behavior of silver chloride is so variable under changing conditions that even the above noted difference is not disconcerting, though it invites further investigation.

### Summary.

To various chloride solutions less than 0.1 *N* in concentration, 0.001 *N* silver nitrate solution was added to incipient precipitation, at 25°. The total silver was invariably given by the sum:  $2 \times 10^{-10}/(MCl) + 3.4 \times 10^{-5}(MCl) + b$ , where  $2 \times 10^{-10}$  is the solubility product,  $3.4 \times 10^{-5}$  a constant possibly connected with a complex of the type  $AgCl_2$ , and *b* apparently is the constant sum of silver chloride in precipitate, in dispersion, and in dissolved molecules. The great difference between this observed total and the minute silver content of filtrates from large precipitates of silver chloride is discussed.

Silver chloride should be most insoluble, at 25°, in 0.0025 *N* chloride solutions.

CAMBRIDGE 38, MASSACHUSETTS.

---

[CONTRIBUTION FROM THE DEPARTMENT OF CHEMISTRY, THE JOHNS HOPKINS UNIVERSITY.]

## THE USE OF THE WATER INTERFEROMETER AS A PRESSURE GAGE.<sup>1</sup>

BY L. VAN DOREN, H. K. PARKER AND P. LOTZ.

Received August 18, 1921.

Nitrogen-filled glass manometers have been used in this laboratory for many years for the measurement of osmotic pressure, although there are certain objections to their use for this purpose; and since it was desired to measure pressures greater than they could withstand (about 100 atmospheres) it was necessary to devise a suitable manometer for this purpose. Frazer and Myrick<sup>2</sup> by use of a resistance pressure gage were able to measure osmotic pressure of concentrated sucrose solutions with approximately the same sensitivity at all pressures, but here also,

<sup>7</sup> Richard and Wells, Ref. 4, p. 29.

<sup>8</sup> See Homochemical Compounds, V. Veimarn, *Kolloid Z.*, **28**, 97 (1921).

<sup>1</sup> This work was assisted by grants from the Carnegie Institution of Washington, and was carried out at the suggestion of J. C. W. Frazer.

<sup>2</sup> Frazer and Myrick, *THIS JOURNAL*, **38**, 1907 (1916).

due to hysteresis effects in the resistance coils and consequent shifting of the zero, the method was not entirely satisfactory. The construction of the apparatus described below which is devoid of these objections, is believed to be satisfactory for this purpose and may also have other similar applications.

The instrument is a modification of the Zeiss water interferometer. Instead of using this instrument in a method for the analysis of solutions it is here used to measure pressure differences.

Figs. 1a and b show respectively the construction of the Zeiss water interferometer and its modifications for use as a pressure gage. In the Zeiss instrument white light from a slit is made parallel by a collimating lens, *L*, and passes through the rectangular openings *R*<sub>1</sub>, *R*<sub>2</sub> as two beams, which, reflected from the mirror, *M*, pass back and unite at

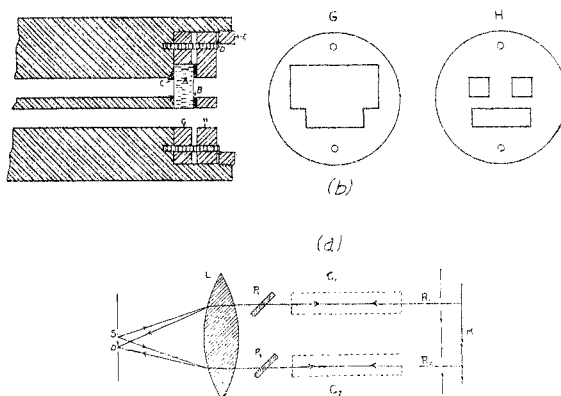

Fig. 1.

O forming a system of interference fringes and are viewed by a suitable eye-piece. The similar chambers *C*<sub>1</sub>, *C*<sub>2</sub>, are placed, one in the path of each beam. When the optical paths are different, as is the case when one of the chambers contains the pure solvent and the other a solution, the interference fringes are displaced to a position at the left or right of O. The displacement is compensated by means of the inclined plate *P*<sub>1</sub>, *P*<sub>2</sub> being fixed. The measurement of the amount of adjustment of *P*<sub>1</sub> necessary to bring back the central bright fringe to the zero position is used as a means of analyzing a solution for a single variable component or several mutually dependent components. The water interferometer adapts itself readily to use as a pressure gage by simply altering the cells *C*<sub>1</sub>, *C*<sub>2</sub> in such a way that the water contained in one of them is kept under atmospheric pressure while that in the other is subjected to the pressure to be determined. For this purpose the cells *C*<sub>1</sub>, *C*<sub>2</sub> are replaced by pressure chambers. These are parallel holes about 6.25 mm. in diameter bored through a solid bronze cylinder and fitted at each end with heavy plate-glass windows *A*, Fig. 1b. Just beneath the pressure chambers the bronze cylinder is provided with a longitudinal slot for beams of light which form the stationary bands of reference.

When pressure is applied to the water in one of the chambers its refractivity is increased and the interference fringes are displayed. The adjustable plate mentioned above enables one to compensate for this

displacement, and it is readily seen that such an instrument after having been calibrated may be used for the measurement of any pressure within the range of adjustment covered by the movable plate.

The chief difficulty to be overcome was to obtain a tight joint between the plate glass windows and the pressure chamber. Fig. 1b shows the construction of one end of the bronze block. A washer C was cut from 3 mm. soft sheet rubber with beveled sides so as to fit the countersunk end of the pressure chamber. This washer is cut slightly oversize, thus giving good contact and insuring a tight joint. A dilute solution of rubber is spread around the washer and hole of the non-pressure chamber, which is not countersunk and requires no washer as no pressure is developed in this chamber.

After assembling and allowing the solvent to evaporate, the chamber is dried thoroughly and a slow stream of gaseous sulfur chloride is blown into the chambers for 10 minutes. This operation vulcanizes the rubber to the required hardness. The glass plate is held in place by a brass plate G, of the same thickness and cut to fit the glass plate snugly. The latter is held tightly against the end of the chamber by a similar brass plate H on which a washer B, made of asbestos and rubber, is placed to take up any unevenness in the glass. Finally, pressure is brought to bear on H by a screw collar E. Some difficulty was experienced in obtaining a suitable washer material to place between the glass and the outside brass plate. When soft thin rubber washers were used the pressure caused them to flow from the small brass section between the pressure chamber and the opening below, thus leaving the glass plate unevenly supported and causing leaks. When harder materials, as leather, were used the windows were frequently broken when pressure was applied. The packing which was successful is used in steam packing and for gaskets and is sold under the trade name of "Durabla Packing." It answered our purpose in having sufficient resilience to take up any unevenness, possessing no tendency to flow, and not requiring any take-up after pressure is applied.

### Increased Range of the Interferometer.

On calibration, the pressure limit of the apparatus, was found to be approximately 60 atmospheres. It was therefore found necessary to devise some means by which the range of the instrument could be increased. This was accomplished by inserting a thin glass plate in the path of the beam passing through the non-pressure chamber, the glass plate being of such thickness that, when inserted, it would compensate for approximately 60 atmospheres. With this plate inserted we thus had a range of from 60 to 120 atmospheres, approximately. The final adjustment for reading is accomplished by the usual method of tilting the glass plate of the interferometer. Thus, by making up several slides with plates of increasing thickness we were able to extend the range of the apparatus to any pressure required.

The glass plates were attached firmly to brass frames by Canada balsam, the plates being machined to fit into slides attached to the water bath of the interferometer.

We found that thin microscope-cover plates were quite regular in thickness and proved easily adaptable to the problem at hand. The plates used varied in thickness from 0.1016 to 0.3556 mm.

The method of mounting these thin glass plates was such that they

could be replaced in exactly the same position and thus any error that would arise from any slight irregularity in the plate was avoided.

### Calibration of Apparatus.

The apparatus was calibrated against an absolute pressure gage in the Geophysical Laboratory.<sup>3</sup> The calibration was made at both 20° and 30°. In the data for Plate 6 it was found necessary to read a different band as our zero point at 30° than was read at 20°, hence the apparent discrepancy in the calibration for this plate. The personal equation in reading the interferometer as used for pressure measurements is considerable but care was taken to calibrate in the same manner as when using the instrument for the measurement of pressure. This instrument has been used satisfactorily for the direct measurement of osmotic pressure as described in the following article.

TABLE I.  
CALIBRATION DATA.

Absolute gage pressure in atmospheres.	Reading on interferometer.			Reading on interferometer.		
	30°.			20°.		
	1.	2.	Mean.	1.	2.	Mean.
	Interferometer Alone.					
24.1	1116	1114	1115	1170	1178	1174
36.6	1759	1752	1756	1807	1808	1808
49.0	2413	2406	2410	2504	2508	2506
55.3	2789	2782	2786	2888	2893	2890
	Plate 6.					
55.3	209	206	207	207	209	208
74.1	1092	1092	1092	1087	1092	1089
102.2	2552	2552	2552	2611	2603	2607
	Plate 3.					
114.6	49	43	46	240	244	242
139.7	1209	1202	1206	1410	1420	1415
167.2	2639	2649	2644	2927	2934	2930
	Plate 8.					
154.7	-296	-297	-297	-57	-63	-60
167.2	254	250	252	480	488	484
192.2	1444	1444	1444	1677	1672	1674
213.8	2537	2535	2536	2846	2854	2850
	Plate 7.					
220.0	.....	.....	.....	-165	-175	-170
244.9	.....	.....	.....	963	928	932
269.8	.....	.....	.....	2180	2180	2180

The difference in the readings at 20° and 30° shows that at a higher temperature the effect of increased pressure on the refractive index diminishes and the magnitude of the difference found by the authors is in

<sup>3</sup> The authors wish to express their thanks for the courtesies extended them by members of the staff of the Geophysical Laboratory.

agreement with the work of Röntgen and Zehnder<sup>4</sup> who measured the effect of temperature on the pressure coefficient of the refractive index. One may also determine from the calibration data above the extent to which the temperature of the instrument must be controlled in order to secure the desired accuracy.

BALTIMORE, MARYLAND.

[CONTRIBUTION FROM THE DEPARTMENT OF CHEMISTRY, THE JOHNS HOPKINS UNIVERSITY.]

## THE OSMOTIC PRESSURES OF CONCENTRATED SOLUTIONS OF SUCROSE AS DETERMINED BY THE WATER INTERFEROMETER.

BY PAUL LOTZ AND J. C. W. FRAZER.

Received August 18, 1921.

Many difficulties are encountered in the direct measurement of the osmotic pressures of solutions among which are those involved in measuring the pressure. The limit of pressure that the glass manometer will stand as found by Frazer and Myrick is about 100 atmospheres. Among the uncertainties involved in the use of gas manometers are the deviation of gases from Boyle's law, and the fact that gas may be occluded between the mercury and the glass, both of which may become appreciable when measuring high pressures. The percentage error involved in reading the levels of the mercury menisci also increases with the compression of the gas and the change of form of the meniscus is not to be disregarded. So the higher the pressure the less accurate the gas manometer becomes.

Frazer and Myrick<sup>2</sup> by the use of the resistance pressure gage were able to obtain a constant sensitivity at all pressures, but owing to certain difficulties such as hysteresis in the resistance coils it was thought wiser to seek a method for measuring high pressures that would be less objectionable.

Berkeley and Hartley<sup>3</sup> determined the osmotic pressure of several solutions up to pressures of 133 atmospheres by applying mechanical pressure and determining the equilibrium pressure by noting the point at which the solvent just ceases to pass through the semipermeable membrane.

In an article by Woods<sup>4</sup> the objection is raised that the osmotic pressure of solutions as measured is not the true osmotic pressure, but of that layer of solutions in immediate contact with the semipermeable membrane

<sup>4</sup> Röntgen and Zehnder, *Wied. Ann.*, **44**, 34 (1891).

<sup>1</sup> This work has been assisted by grants from the Carnegie Institution of Washington.

<sup>2</sup> Frazer and Myrick, *THIS JOURNAL*, **38**, 1907 (1916).

<sup>3</sup> Berkeley and Hartley, *Phil. Trans.*, **206A**, 486 (1906).

<sup>4</sup> Woods, *Trans. Faraday Soc.*, **11**, 29 (1915).